

# ASSEMBLY INSTRUCTIONS

Follow assembly instructions below. Refer to assembly drawings and instructions on the following pages.

- Remove existing bumper, spare tire, carrier and bolted-in cross member behind rear axle.
- For 2-WD and 4-WD trucks bolt on mounting brackets to outside of truck frame. Use straight brackets for trucks with 34" wide frames and formed brackets for trucks with wider frames. (Do not tighten brackets at this time.)

**NOTE:** Do not remove any welded or riveted-in cross members.

- There are four sets of mounting holes in the quic-cush'n II brackets which will give the towbar various heights from the ground. Proper towbar height is 17"-20" from the ground to the top of towbar. By design the top of towbar is in line with the mounting holes in the brackets; therefore measure from the ground to the desired mounting holes and bolt bumper frame to this location.

**NOTE:** On some trucks with heavy duty suspensions, the drawbar will be higher than 20". Mount bumper in the lowest hole on these units.

- Loosely install quic-cush'n II frame assembly between mounting brackets using the proper holes described in Step #3 above and proper holes in quic-cush'n II frame, front to rear, as shown in figure below.
- Loosely install left and right hand diagonal braces to brackets as shown below.

**NOTE:** The diagonal brace will always attach to hole "B" as shown below. On some trucks this hole "B" will be used to attach bumper frame to mounting bracket and diagonal brace.

- Attach load spread supports using appropriate hole locations. Upper or lower holes and forward or aft holes may be used depending upon the make of vehicle and location of bumper.
- Level quic-cush'n II bumper assembly, and tighten all bolts except the diagonal bracket bolts. Torque to specification.
- Install drop center channel to frame assembly. Insert remaining diagonal brace bolts into ends of channel and tighten all bolts. Be careful not to scratch the paint on the truck.

**NOTE:** If optional filler panel is to be used, loosely attach it to the channel before installing channel. (See Page #8.)

- Adjust the 5/8" x 2-1/2" bolt so it contacts the under side of truck frame. Thread bolt upward 1/4" more. This will keep supports under pressure and prevent vibration and noise.
- Torque all load spread support bolts to 85 ft-lbs. Torque 5/8" jam nuts to 170 ft-lbs.
- IMPORTANT:** When complete, check for proper clearances between truck components and bumper assembly. There must be a minimum clearance of 2-1/4", fore and aft, and 1-1/4" above spring casting (Ref. #16) from any obstruction to allow proper and safe operation.
- Grease roller and make certain it rotates freely.

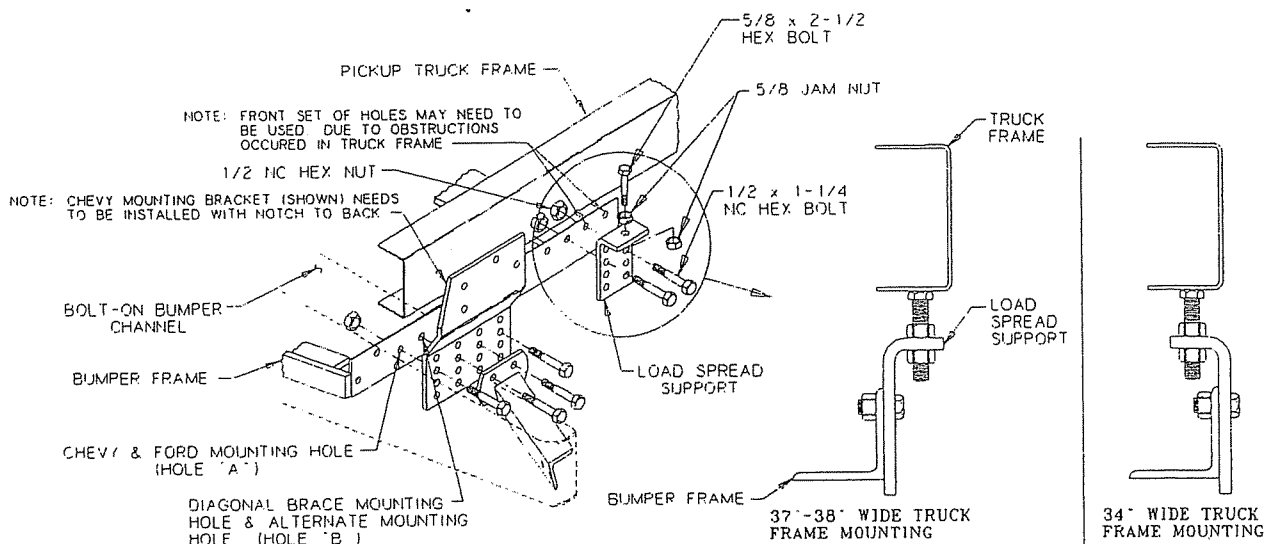

# quic-cush'n II MOUNTING BRACKETS

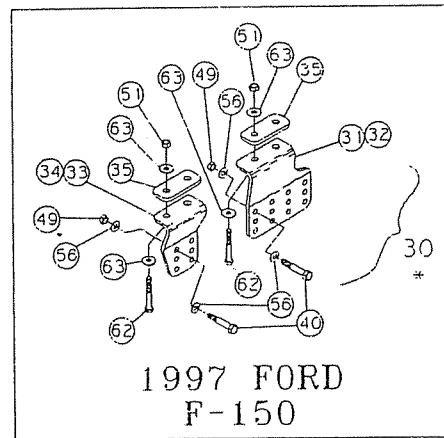
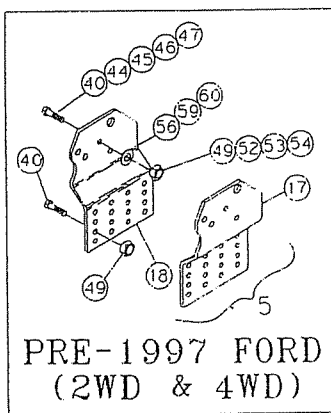
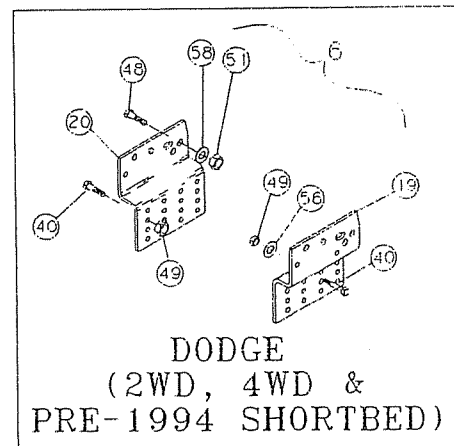
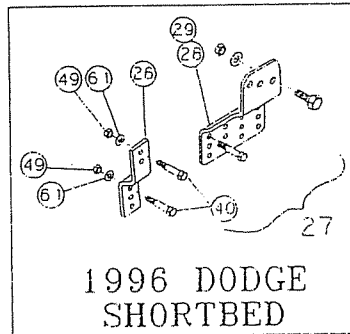
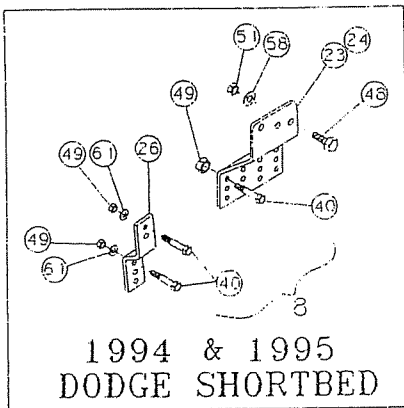
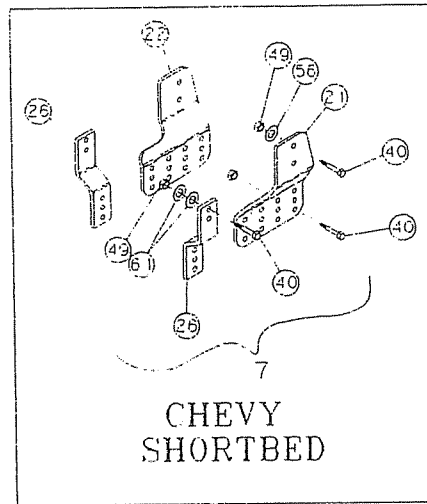
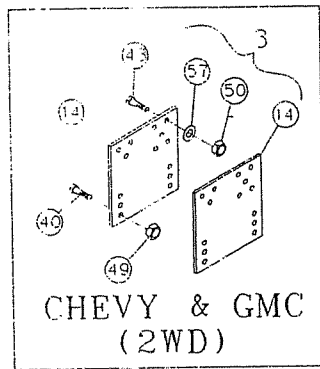

\* SPECIAL INSTALLATION  
SEE ASSEMBLY SECTION  
FOR INSTRUCTIONS

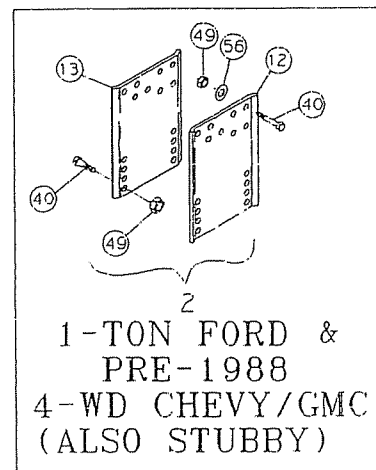

# MOUNTING BRACKET INSTALLATION

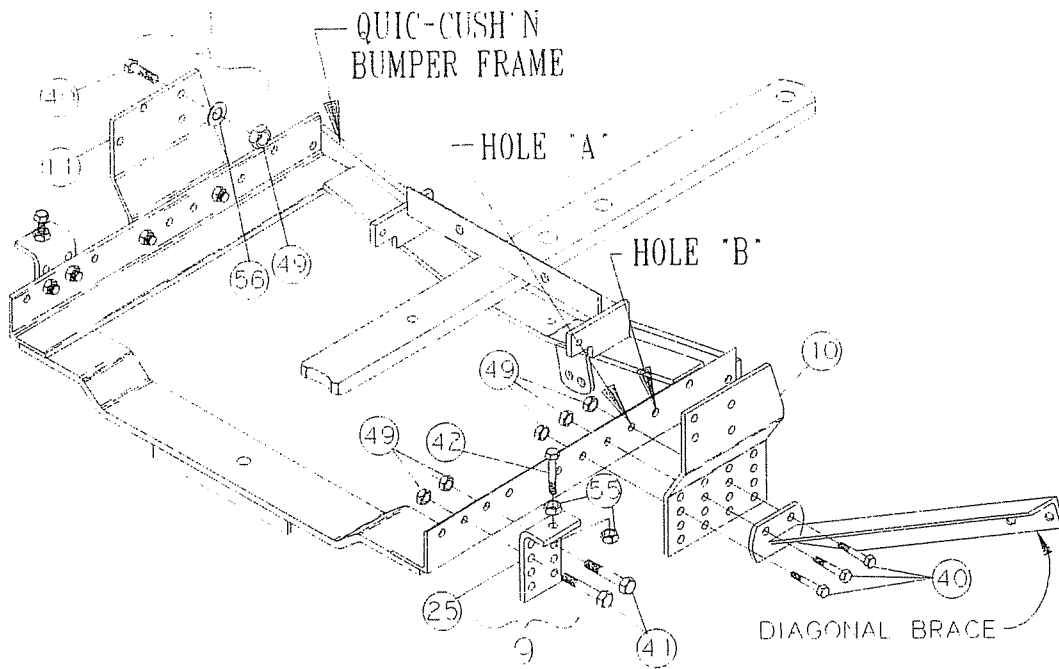

REF. NO.	PART NO.	QTY. NO.	DESCRIPTION	REF. NO.	PART NO.	QTY. NO.	DESCRIPTION
1	47073000	1	38" Mounting Kit - 2WD & 4WD 1988 to Current Chevy & GMC	30	47056200	2	'97 Ford F-150 Mounting Kit (See Pge #4 for special installation)
2	47027000	1	34" Mounting Kit - Pre-1988 4WD Chevy & Stubby and 1-Ton Ford	31	47056230	1	LH Mounting Bracket - '97 Ford F-150
3C				32	47056240	1	RH Mounting Bracket - '97 Ford F-150
4	47024000	1	34" Mounting Kit - 2WD Chevy & GMC	33	47056210	1	LH Front Mounting Bracket - '97 Ford F-150
5	47056100	1	38" Mounting Kit - 2WD & 4WD Pre-1997 Ford	34	47056220	1	RH Front Mounting Bracket - '97 Ford F-150
6	47026000	1	38" Mounting Kit - 2WD, 4WD, 1-Ton Dodge & Pre-1994 Shortbed Dodge	35	47056250	2	Backup Plate
7	47073300	1	Mounting Kit - Chevy & GMC Shortbed	40	16008075	A/R	1/2" x 1-3/4" NC Hex Bolt Gd. 5
8	47026500	1	'94-'95 Dodge Shortbed Mounting Kit	41	16008055	A/R	1/2" x 1-1/4" NC Hex Bolt Gd. 5
9	47058000	1	Front Support Mounting Kit	42	NSI	2	5/8" x 2-1/2" NC Hex Bolt (16901011)
10	47073100	1	LH Mounting Bracket - 2WD & 4WD 1988 Chevy	43	16007065	6	7/16" x 1-1/2" NC Hex Bolt Gd. 5
11	47073200	1	RH Mounting Bracket - 2WD & 4WD 1988 Chevy	44	16009065	2	9/16" x 1-1/2" NC Hex Bolt Gd. 5
12	47028020	1	LH Mounting Bracket - 4WD 1-Ton Chevy & GMC	45	NSI	2	3/4" x 1-1/2" NC Hex Bolt (16012061)
13	47028010	1	RH Mounting Bracket - 4WD 1-Ton Chevy & GMC	46	NSI	2	7/8" x 1-1/2" NC Hex Bolt (16014061)
14	47014000	2	Mounting Bracket - 2WD Chevy & GMC	47	16909055	2	M14-20 x 30.0 Hex Bolt
17	47056110	1	LH Mounting Bracket - 2WD & 4WD Pre-1997	48	NSI	2	5/8" x 1-1/2" NC Hex Bolt (16010061)
18	47056120	1	RH Mounting Bracket - 2WD & 4WD Pre-1997	49	NSI	A/R	1/2" NC Hex Nut (14000801)
19	47026010	1	LH Mounting Bracket - 2WD, 4WD & 1-Ton Dodge & Pre-1994 Shortbed Dodge	50	NSI	6	7/16" NC Hex Nut (14000701)
20	47026020	1	RH Mounting Bracket - 2WD, 4WD & 1-Ton Dodge & Pre-1994 Shortbed Dodge	51	NSI	1	5/8" NC Hex Nut (14001001)
21	47073020	1	LH Mounting Bracket - Chevy Shortbed	52	NSI	2	9/16" NC Hex Nut (14000901)
22	47073030	1	RH Mounting Bracket - Chevy Shortbed	53	NSI	2	3/4" NC Hex Nut (14001200)
23	47026040	1	LH Mounting Bracket - '94-'95 Dodge Shortbed	54	NSI	2	7/8" NC Hex Nut (16014061)
24	47026030	1	RH Mounting Bracket - '94-'95 Dodge Shortbed	55	NSI	4	5/8" NC Hex Jam Nut (14031001)
25	47057000	2	Load Spread Support Bracket	56	NSI	A/R	1/2" Std. Washer (17008001)
26	47073040	2	Front Strap	57	NSI	6	7/16" Std. Washer (17007001)
	47026600	1	'96 Dodge Shortbed Mounting Kit	58	NSI	2	5/8" Std. Washer (17411011)
	47026060	1	LH Mounting Bracket - '96 Dodge Shortbed	59	NSI	2	3/4" Std. Washer (17012001)
29	47026050	1	RH Mounting Bracket - '96 Dodge Shortbed	60	NSI	2	7/8" Std. Washer (17014001)
				61	NSI	4	9/16" ID x 1-3/8" OD Washer (17409010)
				62	16010075	8	5/8" x 1-3/4" NC Hex Bolt, Gd. 5
				63	NSI	16	5/8" Special Washer (17010001)

NSI - NOT A SERVICE ITEM  
A/R - AS REQUIRED



## DODGE SHORTBED BRACKET INSTALLATION

Follow instructions below and refer to assembly drawings and instructions in the quic-cush'n Owner's Manual.

1. Remove existing bumper, spare tire, carrier and bolted-in cross member behind rear axle.

**NOTE:** Do not remove any welded or riveted-in cross members.

2. For 2-wheel drive and 4-wheel drive trucks, bolt mounting brackets to outside of truck frame. (Do not tighten brackets at this time.)

3. There are three sets of mounting holes in the quic-cush'n II brackets that will place the towbar at various heights from the ground. Proper towbar height is 17" - 20" from the ground to the top of towbar. By design the top of the towbar is in line with the mounting holes in the brackets. Therefore, measure from the ground to the desired mounting holes, and bolt bumper frame to this location.

**NOTE:** On some trucks with heavy duty suspensions, the drawbar will be higher than 20"; so mount bumper in the lowest hole on these units.

4. Loosely install quic-cush'n II frame assembly between mounting brackets using the proper holes described in Step #3 above and as shown in figure below.

5. Loosely install left and right hand diagonal braces to brackets as shown below.

**NOTE:** The diagonal brace will always attach to the center two holes on the brackets as shown below.

6. Install drop center channel to frame assembly. Be careful not to scratch the paint on the truck.

**NOTE:** If optional filler panel is to be used, loosely attach it to the channel before installing channel.

7. Attach front strap using appropriate hole locations.
8. Level quic-cush'n II bumper assembly, and tighten all bolts. Torque 1/2" bolts to 85 ft-lbs. Torque 5/8" bolts to 120 ft-lbs.
9. **IMPORTANT:** When complete, check for proper clearances between truck components and bumper assembly. There must be a minimum clearance of 2-1/4", fore and aft, and 1-1/4" above the center spring casting from any obstruction to get proper and safe operation.
10. Grease roller, and make certain it rotates freely.

