

Quic 'n Easy MOUNTING INSTRUCTIONS

1997 FORD F-150/250

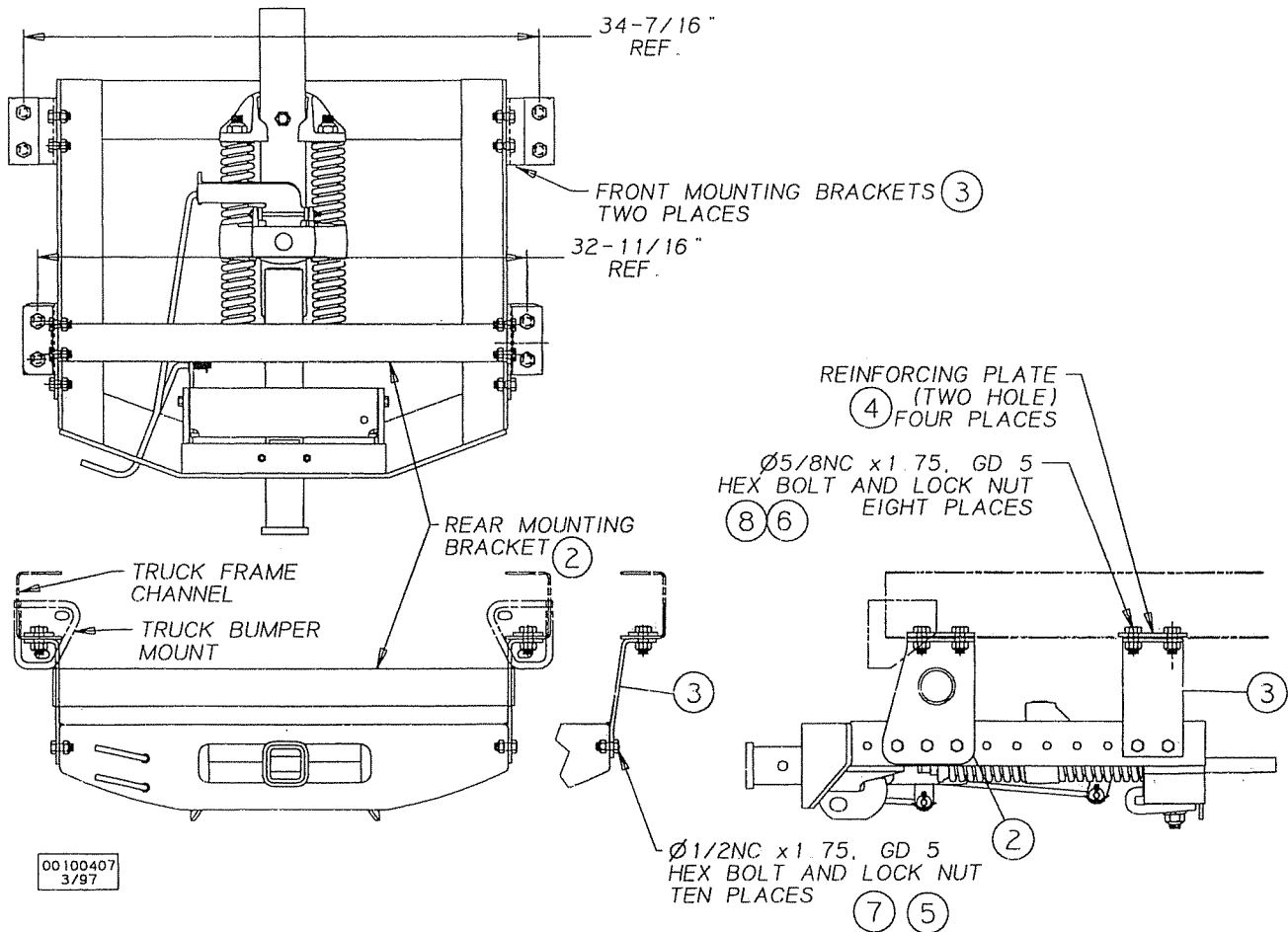

ITEM NO.	PART NO.	QTY	DESCRIPTION
1	47082010	1	Quic 'n Easy Mounting Kit 1997 Ford F-150/250
2	47077490	1	Rear Mounting Bracket
3	47077494	2	Front Mounting Bracket
4	47077495	4	Reinforcing Plate
5	NSI	10	1/2" Stover Lock Nut (14110801)
6	NSI	8	5/8" NC Stover Lock Nut (14111001)
7	16008075	10	1/2" x 1-3/4" NC Hex Bolt, Gd. 5
8	16010075	8	5/8" x 1-3/4" NC Hex Bolt, Gd. 5

NSI - NOT A SERVICE ITEM

ASSEMBLY INSTRUCTIONS

Follow assembly instructions below. Refer to assembly drawings and instructions on previous page.

1. Remove spare tire and tighten spare tire carrier to prevent noise vibration.

NOTE: Do not remove any welded or riveted-in cross members.

2. Place (2) reinforcing plates (Item #4) over holes in truck frame that align with holes in rear mounting bracket (Item #2), insert 5/8" x 1-3/4" bolts (Item #8) through reinforcement plates, truck frame, and rear mounting bracket (Item #2). Install 5/8" stover lock nuts (Item #6) to 5/8" bolts. Snug bolts to hold rear mounting bracket in place, but **do not tighten** hardware at this time.
3. Place (2) reinforcing plates (Item #4) over holes in truck frame that align with holes in front mounting brackets (Item #3), insert 5/8" x 1-3/4" bolts (Item #8) through reinforcement plates, truck frame, and front mounting brackets (Item #3). Install 5/8" stover lock nuts (Item #6) to 5/8" bolts. **Do not tighten** hardware at this time.
4. Install **Quic 'n Easy** frame to (2) front mounting brackets (Item #3) and rear mounting bracket (Item #2) using 1/2" x 1-3/4" bolts (Item #7) 1/2" and stover lock nuts (Item #5). **Do not tighten** hardware at this time.

5. TORQUE ALL BOLTS TO THE SPECIFICATIONS SHOWN:

7/16" diameter grade 5 to.....	55 ft-lbs
1/2" diameter grade 5 to.....	85 ft-lbs
9/16" diameter grade 5 to	125 ft-lbs
5/8" diameter grade 5 to	170 ft-lbs
12 mm diameter (from truck) to	85 ft-lbs
16 mm diameter (from truck) to	170 ft-lbs

6. **IMPORTANT:** When complete, check for proper clearances between truck components and **Quic 'n Easy** receiver hitch assembly. There must be a minimum clearance of 2-1/4", fore and aft, and 1-1/4" above the spring casting from any obstruction to allow proper and safe operation.
7. Slide red plastic handle covers over slide lock handle and pin lever handle.