

Quic 'n Easy MOUNTING INSTRUCTIONS

1988 - 1997 CHEVY/GMC FULL SIZE PICK UP

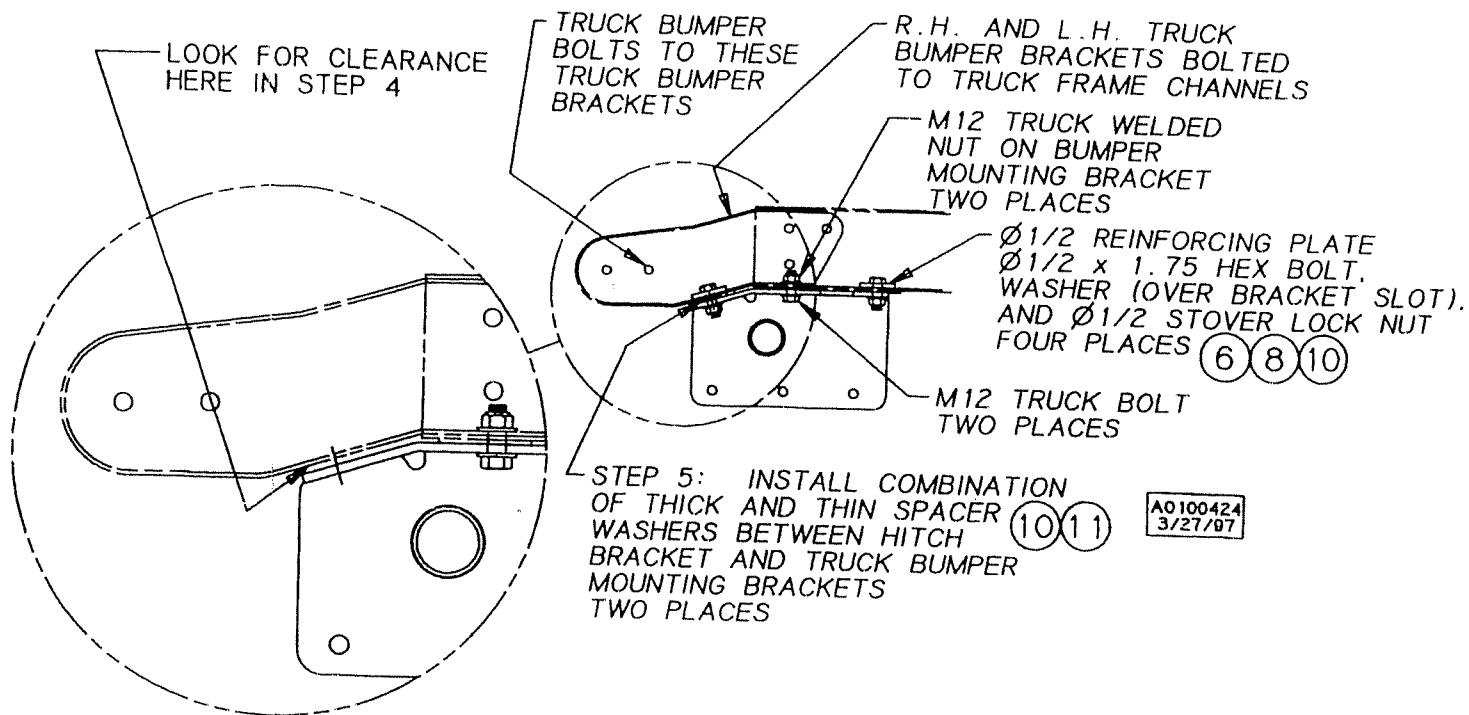

Follow assembly instructions below. Refer to assembly drawings and instructions on previous page.

1. Remove spare tire and tighten spare tire winch to clear hitch and prevent noise vibration.
- NOTE:** Do not remove any welded or riveted-in cross members.
2. Remove (2) vertical M12 truck hex bolts from truck bumper bracket at rear of the truck.
 3. Loosely bolt rear mounting bracket (Item #2) in place with the (2) M12 bolts removed in step #2. Snug the (2) M12 hex bolts and loosen 1/4 turn. Place (2) reinforcing plates (for 1/2" bolt) (Item #5) over holes in the truck frame that align with the holes in the that align with the holes in the rear mounting bracket. Insert (2) 1/2" x 1-3/4" bolts (Item #8) down through the reinforcement plates (for 1/2" bolts) (Item #5), truck frame channel, and rear mounting bracket (Item #2) and install (2) 1/2" special washer (Item #10) and (2) 1/2" stover lock nuts (Item #6). Snug bolts to hold rear mounting bracket in place, but **do not tighten** hardware at this time.
 4. Look for clearance between the rear mounting bracket (Item #2) and the truck bumper mounts at the rear bolt holes in the rear mounting bracket. Due to design differences between truck models (1500, 2500, etc.) and due to assembly tolerances, there may be a clearance problem at this location. If there is not enough clearance to fit a 1/2" standard washer (Item #11), proceed with the assembly. If there is room for one or more washer(s) (thick or thin), determine the number and combination of 1/2" special washer(s) (Item #10) and 1/2" standard washer(s) (Item #11) required and proceed with assembly, but **do not tighten** hardware at this time.

Quic 'n Easy MOUNTING INSTRUCTIONS

1988 - 1997 CHEVY/GMC FULL SIZE PICK UP

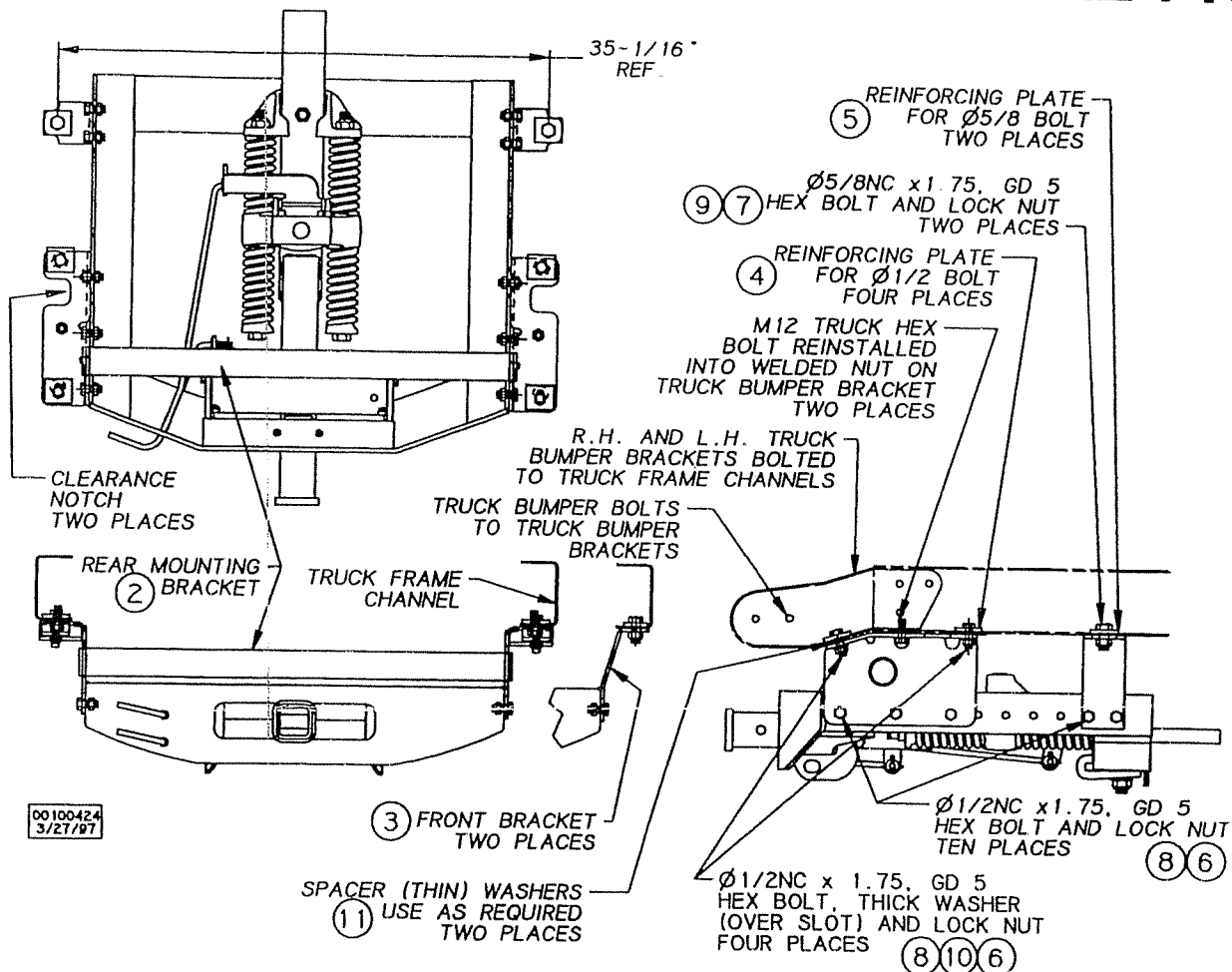

ITEM NO.	PART NO.	QTY	DESCRIPTION
1	47082020	1	Quic 'n Easy Mounting Kit 1988 - 1997 Chevy/GMC (Full Size)
2	47077500	1	Rear Mounting Bracket
3	47077505	2	Front Mounting Bracket
4	47077506	2	Reinforcing Plate (for 5/8" bolt)
5	47077507	4	Reinforcing Plate (for 1/2" bolt)
6	14110801	14	1/2" NC Stover Lock Nut
7	14111001	2	5/8" NC Stover Lock Nut
8	16008075	14	1/2" x 1-3/4" NC Hex Bolt, Gd. 5
9	16010075	2	5/8" x 1-3/4" NC Hex Bolt, Gd. 5
10	17409010	4	1/2" Special Washer
11	17008001	6	1/2" Standard Washer, ZP