

Quic 'n Easy MOUNTING INSTRUCTIONS

1978-1998 F-350

Follow assembly instructions below. Refer to assembly drawings and instructions on previous page.

1. Remove spare tire, spare tire carrier, and bolted-in cross members.

Note: Do NOT remove any welded or riveted-in cross members.

2. Remove truck bumper and brackets from truck frame. Disassemble serrated M14 bolts from truck frame by tapping with a small hammer. Remove truck bumper from truck bumper brackets.
3. Align holes in mounting bracket (Item #2) with holes in truck frame, insert (2) 1/2"x1-3/4" bolts (Item #8) and 1/2" Nyloc lock nuts (Item #6) through top hole in mounting bracket (Item #2). Align truck bumper brackets to outside of mounting bracket and attach with (4) M14 hex bolts and nuts (removed from truck). Snug bolts to hold rear mounting bracket in place, but **do not tighten** hardware at this time.
4. Install right hand front bracket (Item #3) and left hand front bracket (Item #4) to truck frame using 5/8" x 1-3/4" bolts (Item #9), 5/8" standard washers (Item #10) over slot in truck frame only, and 5/8" Nyloc lock nuts (Item #7). **Do not tighten** hardware at this time.
5. Install **Quic 'n Easy** frame to **bottom holes** of right hand front mounting bracket (Item #3), left hand front mounting bracket (Item #4), and rear mounting bracket (Item #2) using 1/2" x 1-3/4" bolts (Item #8) and 1/2" Nyloc lock nuts (Item #6). **Do not tighten** hardware at this time.
6. Attach truck bumper, using **top holes in bumper for F-350 with clearance lights, or in lower holes in bumper for F-350 without clearance lights**, to truck mounting brackets by assembling (2) spacer straps (Item #5) between truck bumper and truck mounting brackets and securing with (4) M12 hex bolts and nuts (removed from truck). **Do not tighten hardware** at this time.
7. TORQUE ALL BOLTS TO THE SPECIFICATIONS SHOWN:
7/16" diameter grade 5 to55 ft-lbs.
1/2" diameter grade 5 to85 ft-lbs.
9/16" diameter grade 5 to125 ft-lbs.
5/8" diameter grade 5 to170 ft-lbs.
12 mm diameter (from truck) to85 ft-lbs.
14mm diameter (from truck) to125 ft-lbs.
16 mm diameter (from truck) to170 ft-lbs.
8. **IMPORTANT:** When complete, check for proper clearance between truck components and **Quic 'n Easy** receiver hitch assembly. There must be a minimum clearance of 2-1/4" fore and after, and 1-1/4" above the spring casting from any obstruction to allow proper and safe operation.
9. Slide red plastic handle covers over slide lock handle and pin lever handle.

47082040

Quic 'n Easy MOUNTING INSTRUCTIONS

1978-1996 F-150
1978-1998 F-250/350

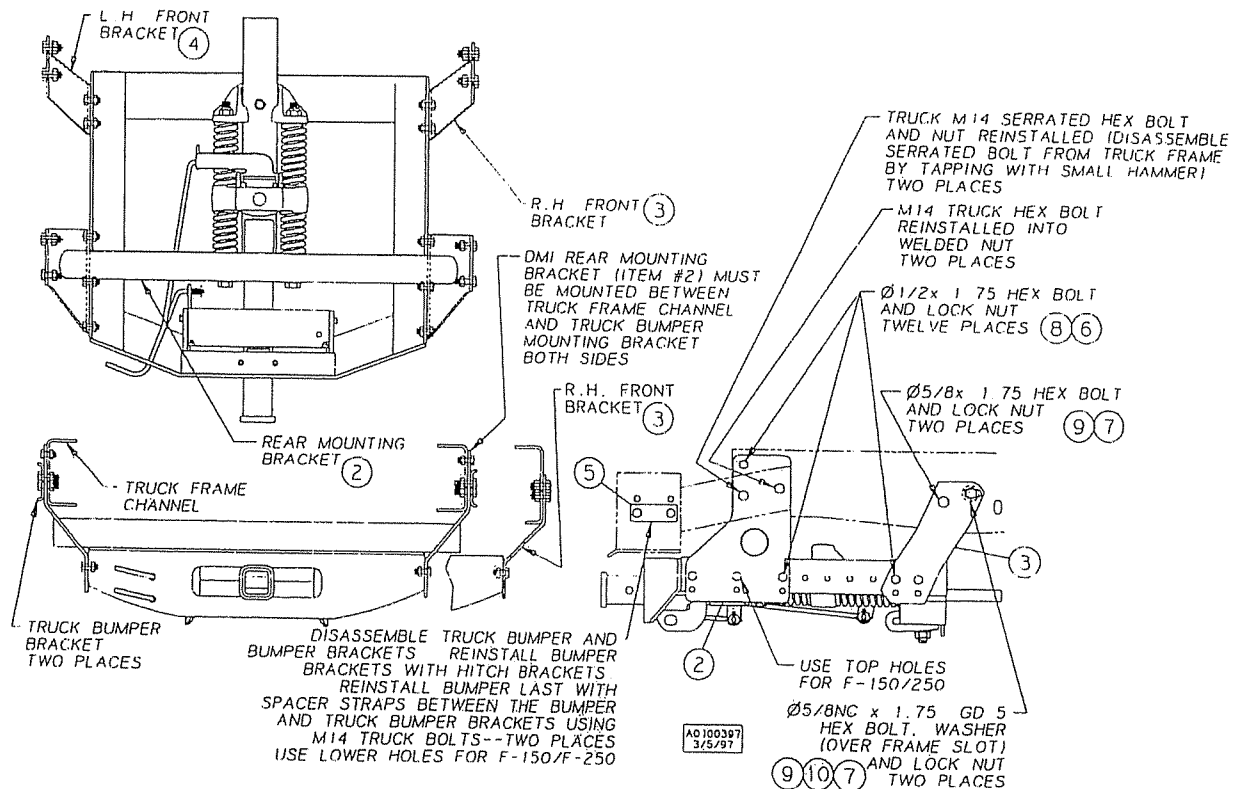

ITEM NO.	PART NO.	QTY	DESCRIPTION
1	47082040	1	Quic 'n Easy Mounting Kit
2	47077550	1	Rear Mounting Bracket
3	47077554	1	Front Mounting Bracket, Right Hand
4	47077555	1	Front Mounting Bracket, Left Hand
5	47077595	2	Spacer Strap
6	14110801	12	1/2"-13 Nyloc Lock Nut
7	14110001	4	5/8"-11 Nyloc Lock Nut
8	16008075	12	1/2"-13x1-3/4" HCS Hex Bolt, Grd. 5
9	16010075	4	5/8"-11x1-3/4" HHCS Hex Bolt, Grd. 5
10	1701001	2	5/8" USS flat washer
11	30003400	2	Plastic handle grip